

SAB Drum Service Brake – AISE N. 11-63 120

Standard AISE N. 11 - 63.120

- Spring application braking
- Thrustor release
- Standard voltage 230/460 VAC 60Hz
- Paint color RAL7021
- Protection level C4M
- Automatic lining wear compensation

- Brake shoe auto-aligning device
- Scale for torque adjustment
- Brake lever synchronization
- Aluminium shoes with non abestos organic linings
- Self lubricated bushings at main hinge points
- Galvanized steel spindles and hinges

Operating conditions

- Ambient temperature: -20°C to 50°C
- Relative humidity no higher than 90%
- IP rating: IP65

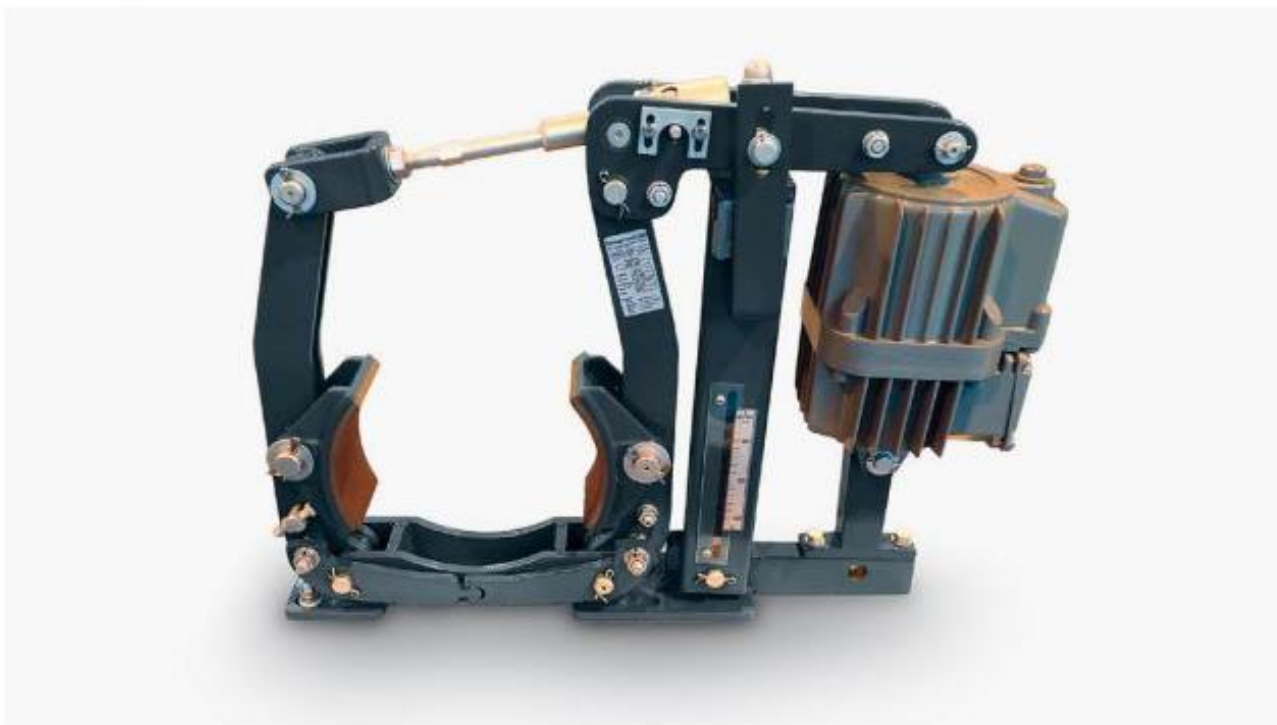

Options:

AV - DV	Thrustor delay: Ascent Valve or Descent Valve
BELS	Brake Engaging Limit Switch
BRLS	Brake Release Limit Switch
HRL	Hand release lever with or without stop
HRLM	Switch for hand release monitoring
LWI	Full lining wear indicators
SPA	Paint according to Customer Specification
SV	Special Voltage

Thrustor Technical Data:

Thrustor type	Power (W)	Current at 400 V (A)	Weight (kg)
TS 230/5	200	0.5	14
TS 300/5	200	0.5	14
TS 500/6	210	0.5	23
TS 800/6	330	1.2	24
TS 1210/6	330	1.2	39
TS 2010/6	450	1.3	39
TS 3010/6	550	1.4	40

SAB Drum Service Brake – AISE N. 11-63 120

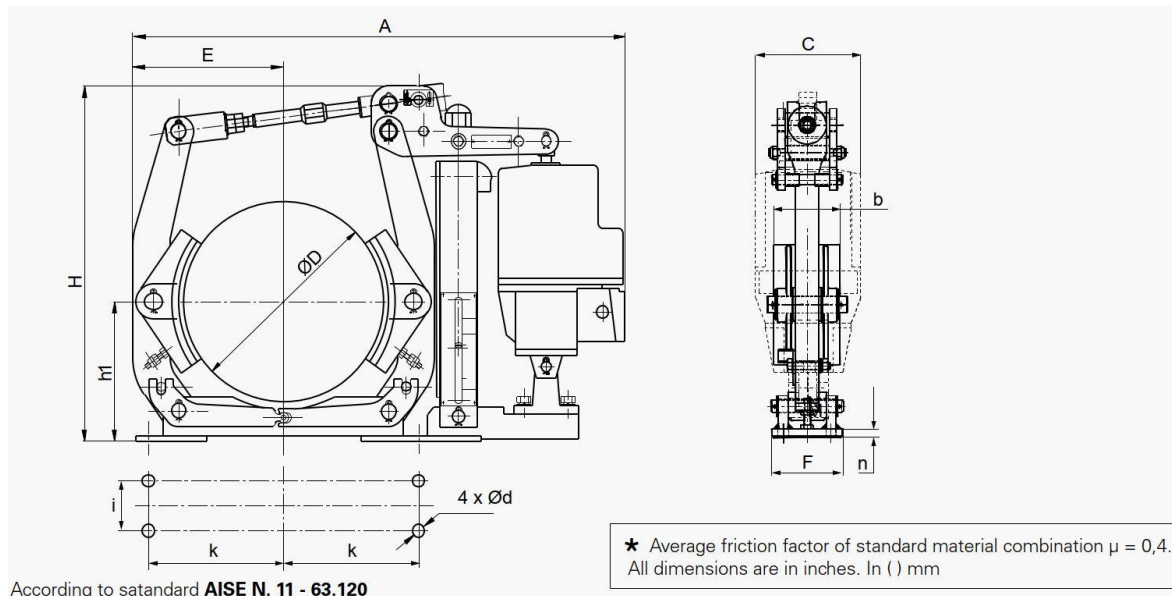

According to standard AISE N. 11 - 63.120

Brake type	Thrustor TS	$M_{DR\ MAX}$ (lb-ft) ★	A	b	C	D	d	E	F	H	h1	i	k	n	Weight (lb)
SAB – 6"	230/5	55-110	22.4	1.65	6.3	6 (152)	3/8 (9.5)	5.5	7.25	16.5	4.75 (120)	3 (76)	4 (102)	0.38	70
SAB – 8"	230/5	85-190	25.16	3.00	6.3	8 (203)	0.69 (17)	6.73	7.28	19.29	7.0 (178)	5.76 (146)	3.25 (83)	0.39	77
	300/5	140-275													84
SAB – 10"	230/5	110-220	28.46	3.54	6.3	10 (254)	0.69 (17)	8.07	7.87	21.65	8.38 (213)	6.26 (160)	4.0 (102)	0.47	100
	300/5	140-280													106
	500/6	220-440													29.92
SAB – 12"	300/5	170-345	32.44	5.51	6.3	12 (305)	0.81 (21)	10.40	11.00	23.86	9.88 (251)	9.0 (228)	5.75 (146)	0.55	155
	500/6	270-540													164
	800/6	430-855													33.6
SAB – 13"	300/5	180-375	32.44	5.51	6.3	13 (330)	0.81 (21)	10.40	11.00	23.86	9.88 (251)	9.0 (228)	5.75 (146)	0.55	160
	500/6	295-590													164
	800/6	460-930													33.6
SAB – 15"	500/6	330-665	40.20	6.49	7.48	15 (381)	1.06 (27)	12.20	13.38	28.15	12.13 (308)	10.76 (273)	7.5 (191)	0.55	300
	800/6	515-1030													308
	1210/6	840-1675													39.76
SAB – 16"	500/6	355-710	40.20	6.49	7.48	16 (406)	1.06 (27)	12.20	13.38	28.15	12.13 (308)	10.76 (273)	7.5 (191)	0.55	304
	800/6	550-1110													308
	1210/6	900-1800													39.76
SAB – 19"	800/6	665-1330	46.46	8.50	7.48	19 (483)	1.06 (27)	14.64	15.35	30.27	13.25 (337)	13 (330)	9.25 (235)	0.79	445
	1210/6	1055-2110													455
	2010/6	1700-3390													39.76
SAB – 23"	1210/6	1220-2440	53.15	10.98	9.45	23 (584)	1.31 (33)	17.60	18.90	41.0	15.88 (403)	16 (406)	11.75 (298)	0.79	695
	2010/6	1900-3870													695
	3010/6	2850-5760													705
	3010/12	3450-6900													
SAB – 30"	1210/6	1400-2800	70.00	14.01	9.45	30 (762)	1.56 (40)	21.57	22.83	53.34	20.75 (527)	19 (482)	15.0 (381)	1.06	950
	2010/6	2360-4720													950
	3010/6	3650-7370													980
	3010/12	4400-8800													